

FLEX

EXTENDS, CONTRACTS, & ZIG-ZAGS FOR OUTBOUND/INBOUND PRODUCT FLOW

DETAILS

WIDTH: 18" / 24" / 30"

* Determined by package size, available conveying area & application-specific needs

EXTENDED LENGTH: 12' to 80'

* Determined by total length needed, including curvatures & obstructions

ELEVATION: 24" - 48" fixed height

SPEED: 20-150 FPM

ROLLER: 1.50" / 1.90" diameter

* 16 ga wall tube with 5/16" cold rolled steel axles, spring retained. Standard bearings are ABEC precision, grease packed

ROLLER CENTERS: 3" / 4" / 5" / 5 1/4"

DRIVE: Located on support structure between frames & between supports for zone accumulation

MOTOR: 90 VDC, supplies up to 16 motors

POWER: 120 Volt, single phase, 60 hertz

FRAME: Steel zinc plated side links with all bolted construction, powder finish leg supports

SUPPORT CENTERS: 6" / 8" casters

WEIGHT CAPACITY: 100lbs per LFT

PRODUCT DETAILS

Keeping up with the continually changing & ever-growing retail, e-commerce & distribution industries can be a daunting task as you strive to stay ahead of the pack. The traditional fixed positioned conveying systems are designed to carry out a single process limiting flexibility required for ever-changing demand. We developed an innovative flexible conveyor system that is expandable, portable, quiet, durable, & cost-effective. Our Flexible Portable Roller Conveyor (FPRC) system can connect in runs up to 80 feet with a single 110v power drop. This versatile system can zig-zag to maneuver around existing equipment or building structures, allowing the creation of a temporary conveyor line to meet ever-changing needs. To complement this system, we developed an innovative powered assist drive to allow the operator to easily maneuver the conveyor line. Our flexible conveying system can provide you with the solution you need to manage ever-changing markets.

FEATURES & BENEFITS

- Safe - No Guarding
- Portable
- Configurable
- 110v Single Phase Power Req.
- Reversible
- Variable speed
- Power Assist
- Fully Assembled for Easy Installation
- Plug & Play
- Requires Minimal Spare Parts
- Smooth Operation
- Quiet

WHAT IT CAN BE USED FOR

- Transportation
- Sortation
- Merging
- Dock Delivery
- Zone Accumulation
- Gapping
- Splitting
- Parcel Fulfillment

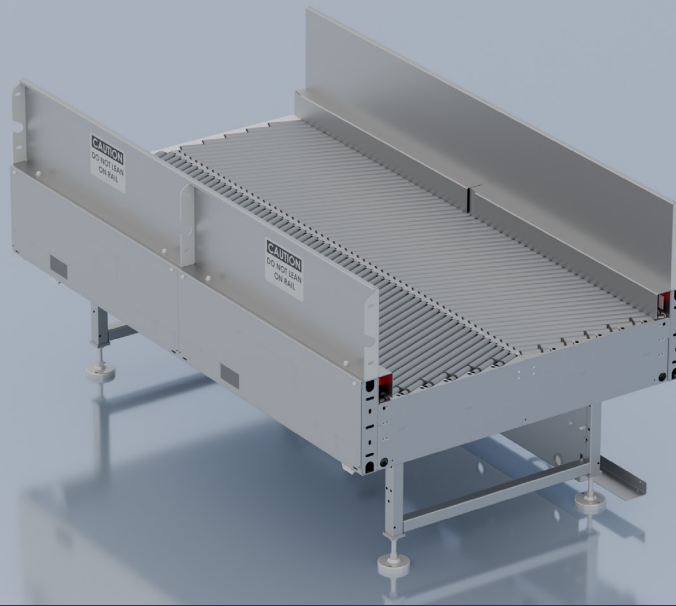

MERGE

CONSOLIDATION OF IRREGULARLY SHAPED PACKAGES TO A SINGLE LANE

DETAILS

WIDTH: 24" up to 84"

*Width is determined by package size, available conveying area, & application-specific needs

LENGTH: 36" to 240"

ELEVATION: 24" TO 120"

SPEED: Application-dependent. Individually controlled fixed speed zones at 25-350+ FPM

ROLLER TYPES: 1.38" / 1.9" / 2.5" standard

GALVANIZED ROLLER ANGLES:

1.38" rollers = 20.7° / 18.6° / 16.4°

1.9" roller = 20.7° / 18.6° / 16.4°

2.5" rollers = 20.2° / 18.5° / 16.8° / 15° / 13.2°

ROLLER CENTERS:

1.38" rollers = 1.5" roller center

1.9" roller = 2.25"

2.5" rollers = 2.75" roller center

FRAME: 12ga for 1.3" rollers or 8ga for 2.5" rollers

GUARDRAIL: Optional 2"-24" tall fixed guardrails

MOTOR: ¾ HP through 2 HP inverter-duty with optional voltages available

PRODUCT DETAILS

The LogistiQ Merge conveys packages from bulk flow or multiple lanes into a single file. This supports downstream activities like singulation, gapping, sortation, or re-direction. The rollers in multiple powered zones are driven by our patented Poly V Hub cartridge bearings. The spring loaded tapered hex axles provide a snug fitment in the frame, & help minimize wear. With multiple angle options, the close roller centers effectively merge & center inbound packages of a variety of shapes & sizes.

FEATURES & BENEFITS

- Conveying Irregular Packages
- Quiet Operation at High Speed
- Can Help Achieve Singulation by Pairing with the LogistiQ Aligner

WHAT IT CAN BE USED FOR

- Merging
- Singulation

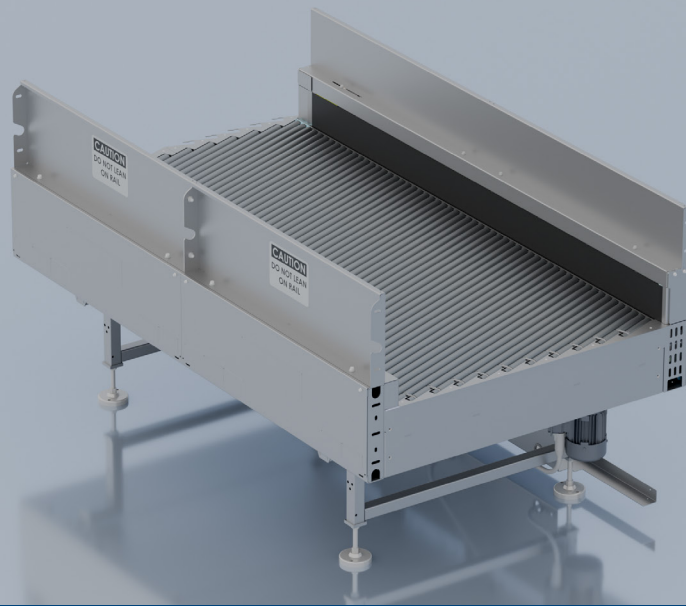

ALIGNER

QUICKLY CONVEYS FROM MULTI LANE FLOW, JUSTIFIES INTO SINGLE LANE FLOW

DETAILS

LENGTH: 60" to 240" or longer

ELEVATION: 24" to 120"

SPEED: Application-dependent. Individually controlled fixed speed zones at 25-350+ FPM

ROLLER TYPE: 1.38" / 2.5" stan. galvanized rollers

ROLLER ANGLES:

1.38" rollers = 20.7° / 18.6° / 16.4°

1.9" rollers = 20.2° / 18.5° / 16.8° / 15° / 13.2°

2.5" rollers = 20.2° / 18.5° / 16.8° / 15° / 13.2°

ROLLER CENTERS:

1.38" rollers = 1.5" Roller center

1.9" rollers = 2.25" Roller centers

2.5" rollers = 2.75" Roller center

FRAME: 12ga or 8ga

MOTOR: ¾ HP through 2 HP inverter duty with optional voltages available

GUARDRAIL: 6" or 12" power face belt, or Durasurf covered guardrail

PRODUCT DETAILS

The LogistiQ Aligner justifies packages from bulk flow or multiple lanes into a right or left side edge. This supports downstream activities like singulation, gapping, sortation, or re-direction. The rollers in multiple powered zones are driven by our patented Poly V Hub cartridge bearings. The spring loaded tapered hex axles provide a snug fitment in the frame, & help minimize wear. With multiple angle options, the close roller centers effectively align inbound packages of a variety of shapes & sizes. The optional vertical power face driven belt side rail helps to square packages prior to exiting the aligner.

FEATURES & BENEFITS

- Conveying Irregular Packages
- Quiet Operation at High Speed
- Can Help Achieve Singulation by Pairing with the LogistiQ Merge

WHAT IT CAN BE USED FOR

- Aligning
- Singulation

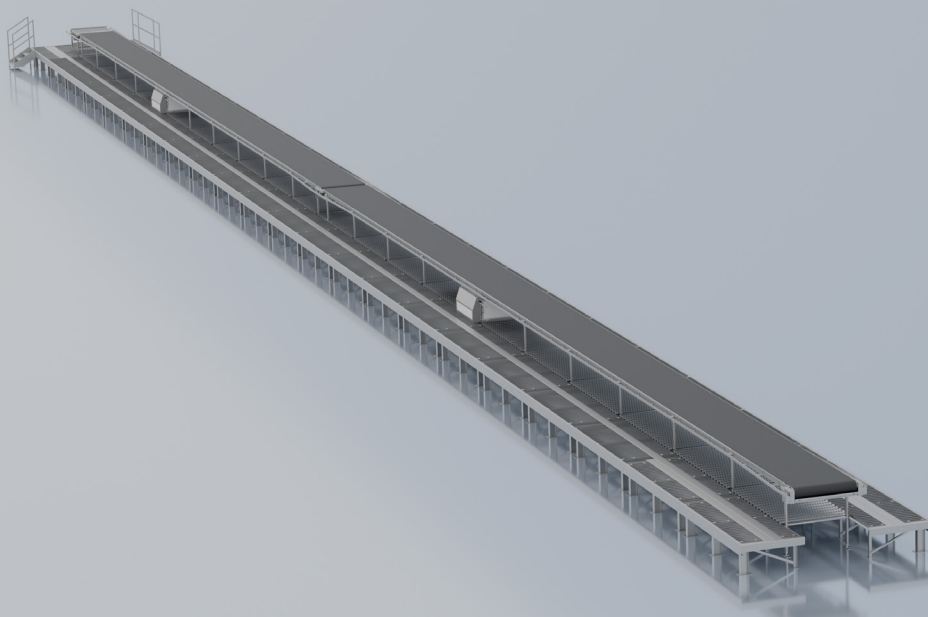

VAN LINE X

QUICK PARCEL & PACKAGE LOADING & UNLOADING

DETAILS

BELT WIDTH: 48"

VARIABLE LENGTH PLATFORMS: Standard 5' or 10'

PLATFORM HEIGHT: 24"

BELT CONVEYOR HEIGHT: 54"

SPEED: As required / reversible

DRIVE: Motorized Pulley Drive up to 10 HP

FRAME: Ergo-friendly design, powder finish

SUPPORTS: Pre-welded heavy duty

PRODUCT DETAILS

Van Line X is an innovative design intended to provide "Standardized" conveyor & platform modular components that are uniform in length, & assembled via well designed bolt together connections. The finished installation is 100% comparable to traditional Van Line installations that are often field fitted & welded together on site.

FEATURES & BENEFITS

- Common Size, Standardized Conveyor Components
- Shortens Installation Time by 30%!
- Ships in a Kitted Format for High Density Freight Consolidation
- Built to End User Specifications
- Shorter Engineering & Manufacturing Lead Times

WHAT IT CAN BE USED FOR

Intended for loading & unloading delivery vans, Van Line X is a direct interchange to traditional Van Line Conveyors & Work Platforms used in the parcel industry for years.

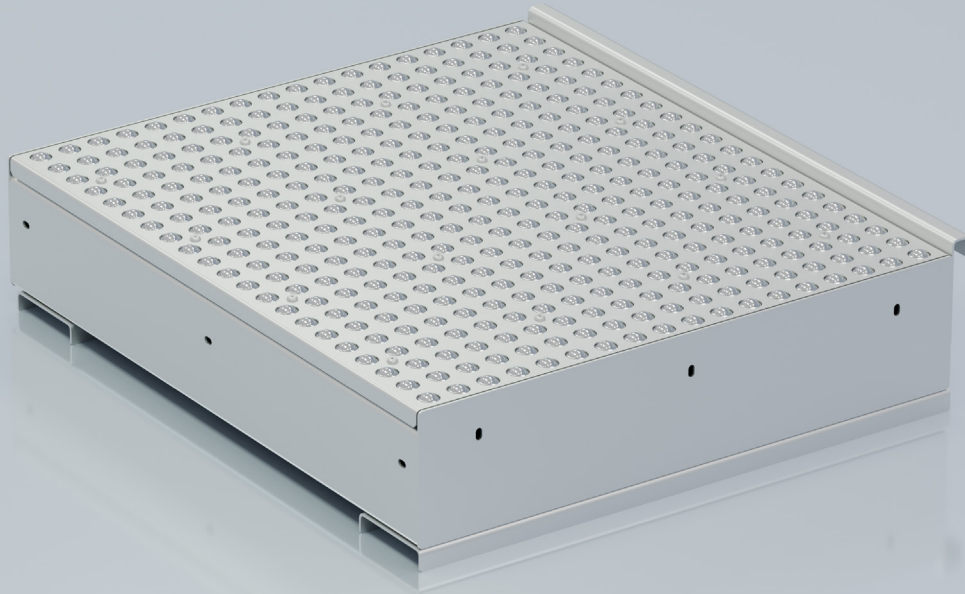

BALL TABLE

ALLOWS FOR EASE OF CONVEYANCE IN ANY DIRECTION

DETAILS

WIDTH: 9" up to 51"

*Width is determined by package size, available conveying area, & application-specific needs

LENGTH: Up to 120"

ELEVATION: As required per application

BALL CENTERS: 2", 3", 4", & 6"

BALL TYPES / CAPACITY PER BALL:

50 lbs. Steel

50 lbs. Nylon

65 lbs. Steel with Flange

75 lbs. Steel

75 lbs. Stainless Steel

FRAME STYLES: BPA, BPB, BPC, & DPD

PRODUCT DETAILS

The Ball Transfer Tables are used to manually rotate, reposition, or remove flat bottom products easily & efficiently. The BPA style is designed to be placed on an existing worktable, sort table, or cart. The BPB style is designed as a free-standing transfer table with smooth edges. The BPC style is built as a complete section that can be utilized as a free-standing unit or coupled to existing sections of gravity roller conveyor & are typically used as a transition or positioning areas within the line. The BPD style plates are designed to replace rollers in existing sections of gravity roller conveyors & are typically used as a transition or positioning area within the line.

FEATURES & BENEFITS

- Convey in Any Direction
- Conveying Irregular Packages
- Multiple Ball Types/Frames for Various Applications
- Minimal Spare Parts

WHAT IT CAN BE USED FOR

- Sortation
- Load Accumulation
- Side Loading
- Unloading
- Rotation

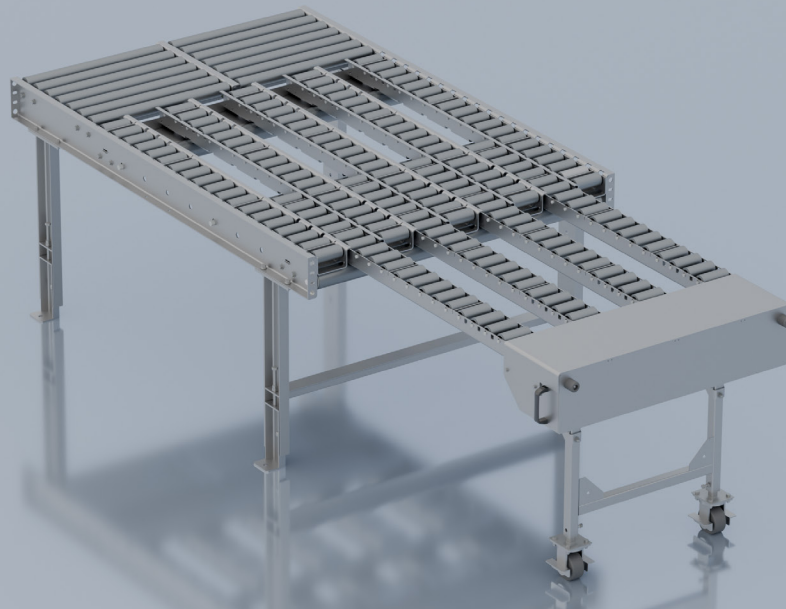

FINGER BRIDGE

CLOSING CONVEYANCE GAPS & MAINTAINING SAME SURFACE ELEVATION

DETAILS

WIDTH: 33" / 45"

*Width is determined by package size, available conveying area, & application-specific needs

LENGTH, COLLAPSED: 87.5"

LENGTH, EXTENDED: 133.5"

OR

LENGTH, COLLAPSED: 99.5"

LENGTH, EXTENDED: 159".5

ROLLER CENTERS: 3"

ELEVATION: 33" +/- 3"

ROLLER TYPE: Standard galvanized roller options:

1.90" diameter, 12 ga. wall tube with 7/16"
Hex cold rolled steel axles, spring retained

2.5" diameter, 11 ga. wall tube with 11/16"
Hex cold rolled steel axles, spring retained

Standard bearings are Semi-precision

SUPPORTS: Heavy-duty Leg supports

Heavy-duty swivel caster with wheel lock
(discharge end only). Self-tracking extension &
retraction

PRODUCT DETAILS

Many sorting facilities have multiple docks receiving or loading packages to & from trailers. In sorting facilities with multiple docks, the need for an aisle way along collector conveyors poses ergonomic challenges. To address this, we developed the Finger Bridge—an extendable solution that closes the surface gap. The retractable fingers, with heavy-duty rollers, create a level surface, eliminating the safety concern of lifting heavy packages over the gap. Operators can efficiently sort packages without lifting & quickly close the unit for egress if needed. The multi-lane design allows easy package orientation for seamless flow onto inbound/outbound conveyors, earning appreciation from operators for its ergonomic benefits.

FEATURES & BENEFITS

- Extendable Conveyor that maintains same surface elevation
- Allows for easy egress to aisle ways with extendable fingers
- Due to construction, provides easy maneuverability for all package sizes
- Multi Lane Gravity Roller Conveyor; 1.9 12g rollers on 2.25 centers
- Swivel lock casters allow for easy extending
- Heavy Duty impact pan to protect the conveyor in robust handling applications

WHAT IT CAN BE USED FOR

- Dock Doors
- Aisle Ways
- Large Package Handling
- Egress In Lieu of Cross-Over/Stairways

PARCEL BELT



INBOUND



OUTBOUND

THE LOGISTIQ ADVANTAGE

Proprietary Product Configurator allows for Automatic 3D models with complete bill of material & 2D drawings based on user inputs for length, height, speed, etc

INDUSTRY NEED

Heavy Duty Bulk Conveyors are needed in many distribution & fulfillment centers.

OUR SOLUTION

We offer a Bolted or Welded conveyor construction that includes heavy duty drives, tail sections with dead end pulleys, nose-over transitions for incline to horizontal conveyors, hitch transitions for horizontal to incline conveyors, intermediate conveyor bed sections with side pans & bottom covers. Intermediate bed sections include slider bed & roller bed designs.

Our unique structural tube supports simplify field installation providing infinite adjustment of elevations along with many common accessories including knee braces, transition plates, adjoining gravity roller conveyors & spiral chutes.

SPECIFICATIONS

STANDARD BELT WIDTHS: 24" / 36" / 42" / 48" / 61"

WHAT IT CAN BE USED FOR

- Distribution & Fulfillment Centers

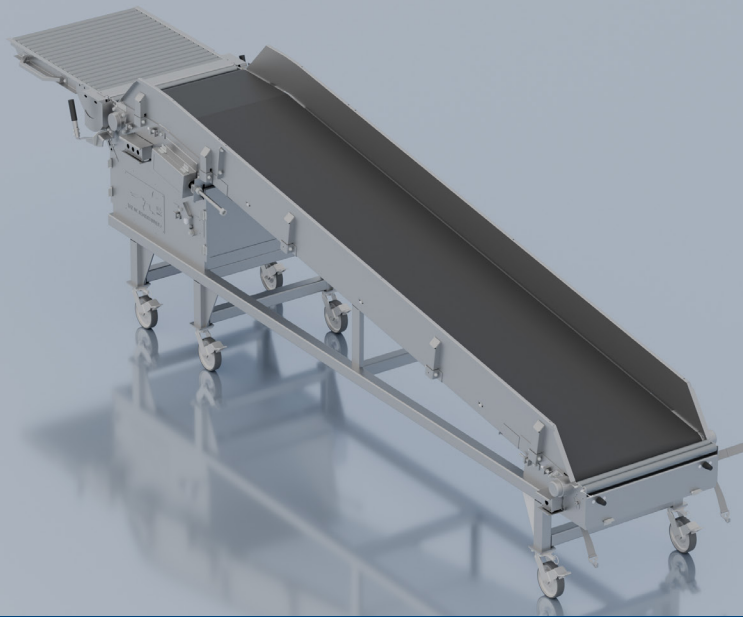

T-SORT BELT

EASY TO USE WHEN UNLOADING NON-CONFORMING PRODUCTS

DETAILS

BELT WIDTH: 35.5"

LENGTH WITHOUT CHUTE: 192"

LENGTH WITH CHUTE: 288.25"

ELEVATION IN-FEED: 31"

ELEVATION DISCHARGE: 54"

SPEED: 60 FPM, Variable Speed

MOTOR: 1 HP, Reversible

DRIVE:

1HP motorized pulley, reversible located within frame

MOTOR: 1 HP, Inverter Duty, Reversible

GUARD RAIL: Removable

SUPPORTS: Heavy-duty Leg supports with swivel caster & wheel lock

PRODUCT DETAILS

We developed a Portable T-Sort Powered Belt Conveyor with a mating portable gravity section designed for mobility. This heavy duty unit is remarkably easy to move, & offers a simple & effective means to handle difficult to convey products in sorting, loading, or unloading applications. The UHMW lined Chute provides a low friction surface at interface points, allowing operators to easily transfer these challenging items on or off the adjoining surfaces. The unit is driven with a 2 HP reversible motorized pulley that uses 115V, 1ph power. Its 20 ft long power cord is supplied with a twist lock plug that stays put. This conveyor is a multi-use unit that is easily deployed for whatever your special use needs might be.

FEATURES & BENEFITS

- Reversible Incline/Decline
- Lift Gate for Egress Access
- 115 V Single Phase Power
- Variable Speed
- Removable Side Rails for Oversized Package
- Optional Gravity Roller In-Feed Conveyor
- Plug & Play Electrical Connections
- 8" Offset Heavy Duty Swivel Locking Casters Allow for Easy Maneuvering

WHAT IT CAN BE USED FOR

- Manual Sort Operations
- Loading & Unloading Transport Vehicles

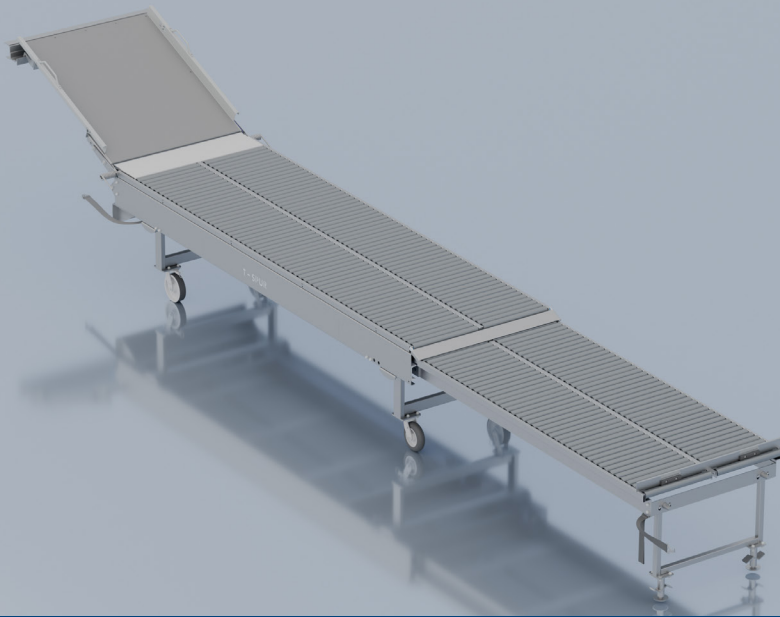

T-SORT ROLLER

EXPANDING & CONTRACTING NEEDS AT LOADING DOCK

DETAILS

WIDTH BETWEEN FRAMES: 42"

LENGTH, COLLAPSED: 144"

STANDARD LENGTH, EXTENDED: Standard 240"

*Self-tracking extension & retraction

PIVOTING LENGTH, EXTENDED: Chute 288.25"

CHUTE: UHMW Lined

ELEVATION: 33" +/- 3"

ROLLER TYPE: 1.90" Dia, 12ga galvanized rollers

ROLLER CENTERS: 2.25"

FRAME: Ergo-friendly design, powder finish

SUPPORTS: Heavy-duty supports & swivel caster with wheel lock (discharge end only)

PRODUCT DETAILS

We developed the Portable T-Sort Roller Conveyor to support customers in quickly expanding their existing manual sort capabilities. Its flexible features allow operators to easily move the large 12 ft long portable conveyor components to a desired location, lock them in place, & extend their length to 20 feet. Multiple segments can achieve as much as 60 feet total extended lengths! The spring loaded chute on the base section is lined with UHMW & can be tilted to connect to an adjoining conveyor at 90 degrees, offering a low friction sorting surface to the newly created conveyor lane. Customers have reported significant increases in productivity related to the deployment of these relatively low cost units to existing operations, without the need for disruptive, & expensive system expansions.

FEATURES & BENEFITS

- Available in (3) 20 ft Extendable Mating Sections
- 8" Offset Heavy Duty Swivel Locking Casters allow for Easy Maneuvering
- Torsion Spring Loaded Pivoting Chute
- Dual Lane 1.9 16g Rollers on 2.25 Centers
- Easy in & Out Extension

WHAT IT CAN BE USED FOR

- Manual Sort Operations
- Loading & Unloading Transport Vehicles

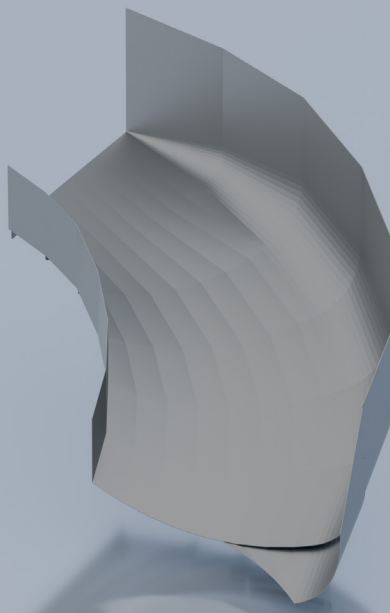

SPIRAL CHUTES

SMOOTH, LOW FRICTION PACKAGE MOVEMENT

DETAILS

WIDTH: 36" / 42" / 48" / 60"

*Width is determined by package size, available conveying area, & application-specific needs

INNER RADIUS: 30" - 36"

IN-FEED-DISCHARGE DROP: 29.5" / 40.5"

STANDARD ANGLES: 90° / 60° & 45°

FRAME:

12ga-14ga, Galvanized, Optional Durasurf lining

SUPPORTS:

Optional supports can be added if free standing

PRODUCT DETAILS

A highly efficient delivery aid the Gravity Spiral Chute is widely utilized in distribution & fulfillment centers for seamless package flow management. This device is designed to facilitate the smooth & frictionless movement of packages, ensuring optimal efficiency thanks to the low coefficient of friction from the durasurf lining, allowing packages to be conveyed effectively. Used mainly in distribution & fulfillment centers for package flow.

FEATURES & BENEFITS

- Low Coefficient of Friction Allows for Packages to Move
- Low Coefficient of Friction Allows for Damp Packages to Maintain Speed
- Self-Starting at Angles up to 10 Degrees Less than Standard Steel Chutes
- Various Materials are Available to Support Specific Package Weights
- Delivered Assembled for Fast & Simple Installation
- Fully Customizable

WHAT IT CAN BE USED FOR

- Distribution & Fulfillment Centers
- Commonly used with Heavy Duty Bulk Parcel Belt Conveyors

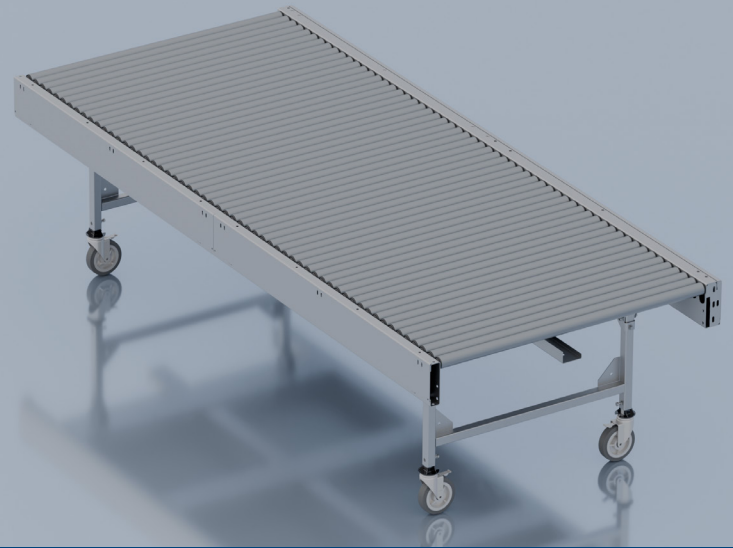

MPRC+

QUICKLY DEPLOYABLE CONVEYANCE SYSTEM

DETAILS

CONVEYING WIDTH: 36" OR 48"

The effective conveying width is determined by package size, available floor space, & application specific needs

CONVEYING ELEVATION: 24" - 48"

Standard conveying elevation is 32", but load & unload areas can be lower or higher as needed. Elevations higher & lower than this range can be achieved on a custom basis

LENGTH (STRAIGHT): 60" / 120"

The standard individual straight section is 120" long; these can be coupled together for runs of any length needed. Lengths other than the standard 60" & 120" are available on a custom basis but need to be divisible by the roller centers

DEGREE (CURVED): 30° / 45° / 60° / 90°

90° turns are standard on most systems, but 30°, 45°, & 60° turns are available as needed for special layout situations

PRODUCT DETAILS

We developed an innovative modular conveyor system that is configurable, portable, quiet, durable, & cost-effective. Our Modular Portable Roller Conveyor Plus (MPRC+) system can connect in straight runs up to 80 feet with a single 110v power drop. The system can combine with powered curves to maneuver around existing equipment or building structures. Our configurable conveying system can provide you with the flexibility you need to manage ever-changing markets. What makes this stand out from our standard MPRC is the optional feature for close roller spacing, along with covered bands. Standard spacing is at a 2.1" roller center.

FEATURES & BENEFITS

- Prevents Wear & Tear
- Protects Operators
- Improved Durability, Lower Maintenance

WHAT IT CAN BE USED FOR

- Transportation
- Sortation
- Merging
- Dock Delivery
- Zone Accumulation
- Creating Gaps
- Parcel Fulfillment

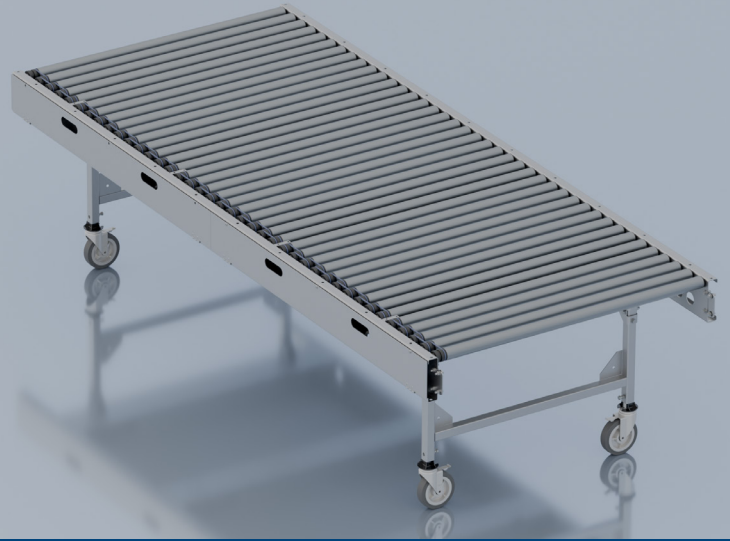

MPRC

QUICKLY DEPLOYABLE CONVEYANCE SYSTEM

DETAILS

CONVEYING WIDTH: 36" OR 48"

The effective conveying width is determined by package size, available floor space, & application specific needs

CONVEYING ELEVATION: 24" - 48"

Standard conveying elevation is 32", but load & unload areas can be lower or higher as needed. Elevations higher & lower than this range can be achieved on a custom basis

LENGTH (STRAIGHT): 60" / 120"

The standard individual straight section is 120" long; these can be coupled together for runs of any length needed. Lengths other than the standard 60" & 120" are available on a custom basis but need to be divisible by the roller centers

DEGREE (CURVED): 30° / 45° / 60° / 90°

90° turns are standard on most systems, but 30°, 45°, & 60° turns are available as needed for special layout situations

PRODUCT DETAILS

Keeping up with the continually changing & ever-growing retail, e-commerce and distribution industries can be a daunting task as you strive to stay ahead of the pack. The traditional fixed positioned conveying systems are designed to carry out a single process, limiting flexibility required for ever-changing demand. We developed an innovative modular conveyor system that is configurable, portable, quiet, durable, & cost-effective. Our Modular Portable Roller Conveyor (MPRC) system can connect in straight runs up to 80 feet with a single 110v power drop. The system can combine with powered curves to maneuver around existing equipment or building structures. Our configurable conveying system can provide you with the flexibility you need to manage ever-changing markets.

FEATURES & BENEFITS

- Safe - No Guarding
- Portable
- Configurable/Re-Configurable
- 110v Single Phase Power Req.
- Reversible
- Variable Speed
- Close Roller Centers
- Fully assembled for Easy Installation
- Plug & Play
- Requires Minimal Spare Parts
- Smooth Operation
- Quiet

WHAT IT CAN BE USED FOR

- Transportation
- Sortation
- Merging
- Dock Delivery
- Zone Accumulation
- Creating Gaps
- Parcel Fulfillment

MPRC+ SYSTEM LAYOUT



1W1F

A single-lane system with (1) runout for transport or sorting. Shown with (2) dock conveyors.



2W2F

A dual-lane system with (2) runouts for transport or sorting. Shown with (3) dock conveyors. Opportunity at dock to sort to the (2) destination runouts.



2W3F

A dual-lane system with (3) runouts for transport or sorting. Shown with (4) dock conveyors. Opportunity at dock sort to runout (1), or runouts (2) & (3). A sort position further downstream provides sorting to runout (2) or if unnamed product will travel to runout (3).



2W4F

A dual-lane system with (4) runouts for transport or sorting. Shown with (5) dock conveyors. Opportunity at dock sort to runouts (1) & (2), or runouts (3) & (4). Downstream sort positions provide sorting to first of (2) runouts, or if unnamed, product runs to last runout pair.

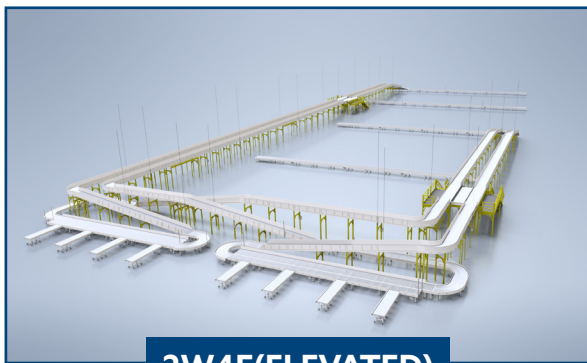

2W4F(ELEVATED)

A dual-lane system with (2) elevated sides of (2) lanes each. (4) runouts for transport or sorting. Shown with (8) dock conveyors. Opportunity at all dock positions to sort. One side feeds runouts (1) & (2), the other feeds runouts (3) & (4). If unnamed, product runs to last pair.

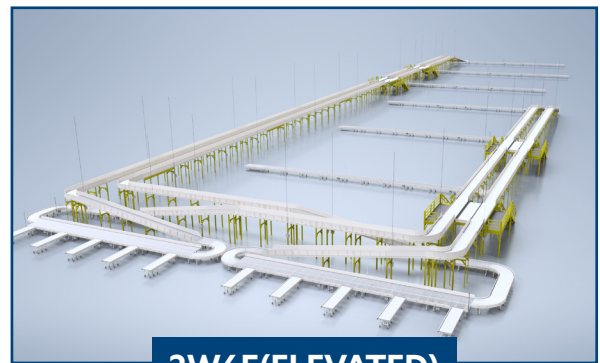

2W6F(ELEVATED)

A dual-lane system with (2) elevated sides of (2) lanes each. (6) runouts for transport or sorting. Shown with (10) dock conveyors. Opportunity at all dock positions to sort. One side feeds runouts (1) thru (3), the other feeds runouts (4) thru (6). If unnamed, product runs to last pair.

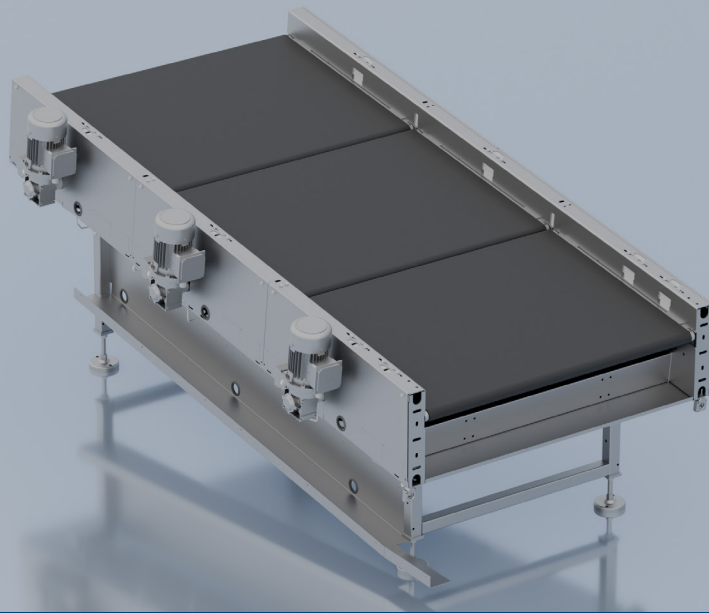

GAPPER

MULTI-SECTION BELT CONVEYOR THAT CREATES SPACE BETWEEN PACKAGES

DETAILS

WIDTH: Application Dependent

*Width is determined by package size, available conveying area, & application-specific needs

BELT WIDTH: Application Dependent

LENGTH: Application Dependent

SPEED: Variable FPM

FRAME: Frame: 8ga, 12 ga slider bed

MOTOR: AC or DC

FRAME: Ergo-friendly design, powder finish

GUARDRAIL: 4" both sides

ELEVATION: Variable, Standard 32" to 48"

PRODUCT DETAILS

The gapper is a multi-section conveyor that is used to create gap spacing between packages during automated sortation. This helps to facilitate the scanning, weighing, & sorting of items. This conveyor is specifically designed to support down-stream functions. With a single 480V speed control box per section allowing you to adjust speeds where needed.

FEATURES & BENEFITS

- Static Gapping
- Dynamic Gapping
- Support Downstream Functions

WHAT IT CAN BE USED FOR

- Sortation
- Product Sizing
- Scanning
- Weighing
- Product Separation

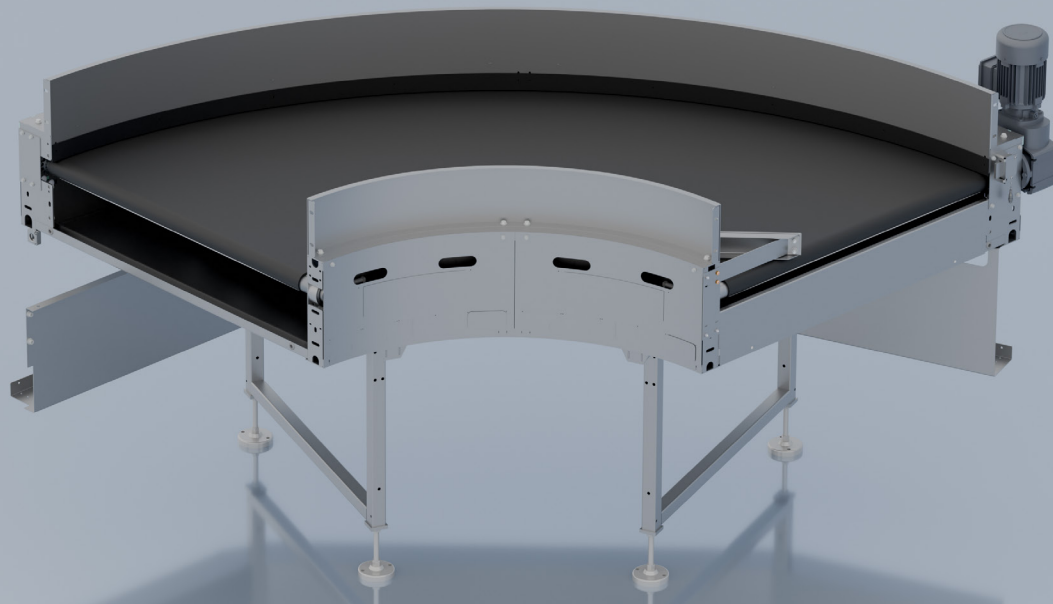

BELT CURVE

EFFECTIVE DIRECTIONAL CHANGE OF PACKAGES

DETAILS

BELT WIDTH: Up to 60"

*Width is determined by package size, available conveying area, & application-specific needs

SPEED: Variable FPM

FRAME: 10GA, 16" deep

MOTOR: Application Dependant

GUARDRAIL: Optional

ELEVATION: 32" / 48" Standard

ARC: 45° / 90° / 180°

PRODUCT DETAILS

We developed our Belt Curve to effectively change application direction for packages that are routinely handled on belt conveyors. Various radiuses available to meet specific needs.

FEATURES & BENEFITS

- Smooth Product Transfers
- Low Noise
- Durable Construction

WHAT IT CAN BE USED FOR

- Help with Facilitation of Various Building Layouts
- Directional Changes for Products Handled on Belt Conveyors
- Maintaining Product Orientation, Directionally
- Handling of Irregularly Shaped Products

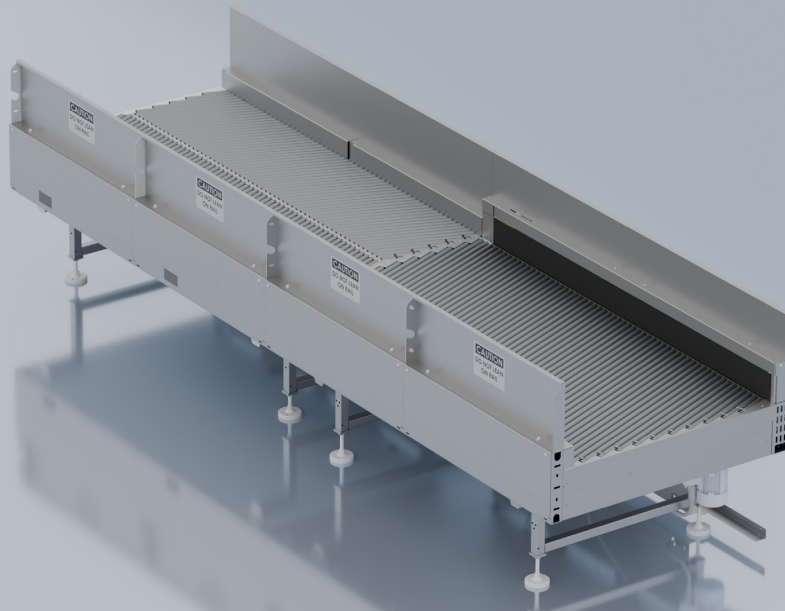

LOGISTIQ SMALL PACKAGE SINGULATOR

CONVERTS BULK FLOW PACKAGES INTO SINGLE FILE FLOW

DETAILS

LENGTH:

ALIGNER: 60" - 240"

MERGE: 36" - 240"

ELEVATION: 21" Minimum

SPEED: Application-Dependent

ROLLER TYPE: 1.38", 1.9" 2.5" stan. galvanized

ROLLER ANGLES: See merge & aligner sheet

ROLLER CENTERS: See merge & aligner sheet

FRAME: 12ga or 8ga

MOTOR: ½ HP through 2 HP inverter duty with optional voltages available

GUARDRAIL:

ALIGNER: 2" - 24"

MERGE: 6" or 12" power face belt, or Durasurf covered guardrail

WIDTH:

ALIGNER: 24" - 48"

MERGE: 36" - 84"

ALIGNER VERTICAL BELT: 6" & 12" wide

PRODUCT DETAILS

The LogistiQ Singulator, with 9 individually and dynamic controlled speed zones, conveys packages from bulk flow or multiple lanes in to a single file flow, where the packages will then be aligned to the left or the right side prior to discharge, on the downstream gapping conveyor.

The rollers in multiple powered zones are driven by Poly V belts using our patented Poly V cartridge bearing hub. The spring loaded tapered hex axles provide a snug fitment in the frame, & help minimize wear. With multiple angle options, the close roller centers effectively align inbound packages of a variety of shapes & sizes. The optional vertical power face driven belt side rail helps to square packages prior to exiting the Singulator.

FEATURES & BENEFITS

- Close Roller Spacing Accommodates Irregular Packages
- Extremely Quiet Operation at Speeds of 650' per min or more
- Designed with Ease of Maintenance in mind

WHAT IT CAN BE USED FOR

- Used to singulate packages for sorting applications via merging, aligning

MATERIAL TO BE HANDLED

HEIGHT: Min 0.5" Max 26"

LENGTH: Min 6" Max 42"

WIDTH: Min 4" Max 33"

WEIGHT: Max 50lbs

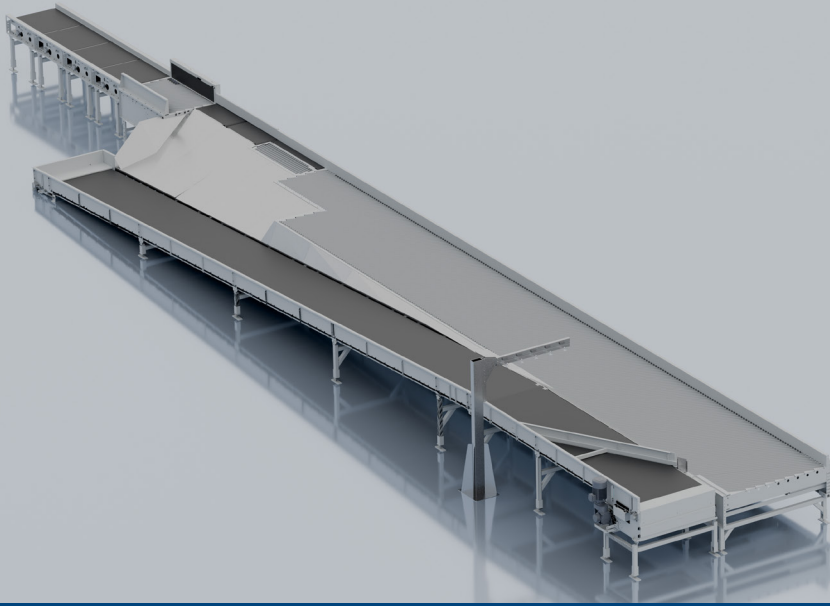

LOGISTIQ LARGE PACKAGE SINGULATOR

CONVERTS BULK FLOW PACKAGES INTO SINGLE FILE FLOW

DETAILS

OVERALL LENGTH WITH MERGE, ALIGNER, & GAPPER: 92' 2"

EFFECTIVE WIDTH OF SINGULATOR: 84-5/8"

OVERALL WIDTH OF LPS: 15'4"

TOP OF ROLLER: 32"

INFEEED SPEED: Up to 410 FPM

DISCHARGE SPEED: Up to 730 FPM

EFFECTIVE WIDTH OF RECIRC: 48-72"

GALVANIZED ROLLERS: 2.50" OD

ROLLER CENTERS: 2.819"

FRAME THICKNESS: 3/16"

GUARDRAIL: 8" or application dependent

ROLLER SKEW: 20 degrees

MOTORS: 1HP to 2HP and 7.5HP on Recirculation Belt

MOTOR CONTROLLER: 460V/3PH/60Hz

FULL LOAD AMPS: Roughly 100

PRODUCT DETAILS

The LogistiQ Large Package Singulator conveys packages from bulk flow or multiple lanes in to a single file flow, where the packages will then be aligned to the left or the right side prior to discharge, on the downstream gapping conveyor.

The rollers in multiple powered zones are driven by Poly V belts using our patented Poly V cartridge bearing hub. The spring loaded tapered hex axles provide a snug fitment in the frame, & help minimize wear. With multiple angle options, the close roller centers effectively align inbound packages of a variety of shapes & sizes. The optical vertical belt side rail squares packages before they exit the Singulator.

FEATURES & BENEFITS

- Majority of maintenance can be performed from above or on the platform side of the conveyor
- Low noise with speeds up to 650' or more
- Integrated controls
- Externally frame-mounted VFDs for ease of installation, maintenance, and troubleshooting

WHAT IT CAN BE USED FOR

- Used to put packages in single file for metering and sortation

OPTIONS

- Gapping conveyors
- Scanners
- Dynamic divert modules
- Over head conversion systems
- Side by side eliminator
- Metering conveyor
- Aligner
- Gapper

MATERIAL TO BE HANDLED

BOX:

HEIGHT: Min 0.75" Max 36"

LENGTH: Min 4" Max 60"

WIDTH: Min 4" Max 36"

WEIGHT: Max 100lbs

POLY BAG:

HEIGHT: Max 4"

LENGTH: Max 25"

WIDTH: Max 14"

WEIGHT: Max 10lbs

RNC BAG:

HEIGHT: Max 15"

LENGTH: Max 34"

WIDTH: Max 30"

WEIGHT: Avg 30lbs

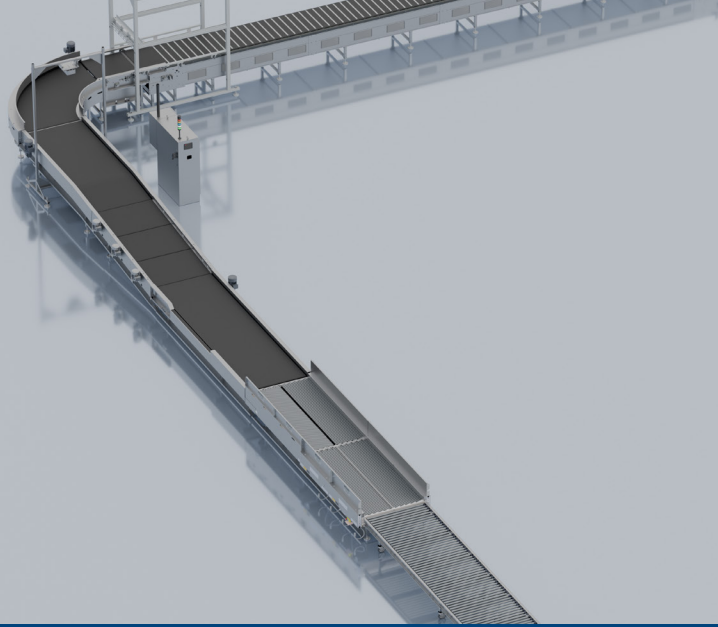

THE LOGISTIQ SORTATION SYSTEM

SINGULATES, GAPS, SCANS, AND SORTS

DETAILS

LENGTH: Application Dependent

HEIGHT: 32" - 48"

ERGONOMIC HEIGHT: 32"

WIDTH: Application Dependent

RANGE OF GAPPING: 4" Minimum

MATERIAL TO BE HANDLED:

BOX:

HEIGHT: Min 0.5" Max 26"

LENGTH: Min 4" Max 42"

WIDTH: Min 3" Max 33"

NON-BOX:

HEIGHT: Min 0.12" Max 5"

LENGTH: Min 4" Max: 16"

WIDTH: Min 3" Max 13"

WEIGHT: Max 50lbs

*EQUIPMENT INCLUDED:

Mechlite, Gapper, Singulator

**Will integrate with Sorters

PRODUCT DETAILS

The LogistiQ Sortation System takes bulk package flow and sorts to individual bins with minimal associate interaction. The modular design allows for features to be added or removed as necessary for the application.

The system consists of a Singulator to condition the packages into a single file line that is aligned to one side. These packages pass through a problem solving workstation where an associate eliminates shingled and stacked packages. After culling, a gapping belt ensures that a 4" gap is created between each package. Each package is scanned to identify the destination sort location. The packages progress down a sorter to the desired destination where they are diverted into a specific Automatic Storage Device. Operators man the Automatic Diverting Devies to unload packages to their delivery location. Packages that don't sort progress to a collection area.

FEATURES & BENEFITS

- Can handle a wide variety of package types from boxes to poly bags
- Modular design allows it to fit in any configuration
- Designed to handle 5500PPH
- Runs quietly and safely to allow associates around the system
- Cetralized controls on one control panel
- Singulation to end of scan in under 48'

WHAT IT CAN BE USED FOR

- Last Mile Sortation
- Like Package Grouping
- Singulation: Turn bulk package flow into aligned even flow
- Gapping: Space out aligned packages
- Scanning: Bar code reading



AUTOMATIC STORAGE DEVICE

ACCUMULATES DIVERTED PACKAGES AND RAISES TO ERGONOMIC PICK HEIGHT

DETAILS

BELT MAX VOLUME: 40+ Cubic Foot

MAX LOAD RATING: 500lbs

WIDTH: 94"

DEPTH: 45"

HEIGHT OVER ALL: 56"

Note standard size. Custom sizes available per application

PRODUCT DETAILS

The LogistiQ Automatic Storage Device is designed to receive packages that come from a sorter, for example a vertical cross belt sorter. With the use of a low friction and impact resistant belt that will automatically raise and lower based on the incoming packages. This allows for the ability to maintain an optimal ergonomic pick height for an associate. The attached chute is covered with a low friction UHMW and is adjustable to select degree modification to maintain package speed as it enters the hamper belting. This assists in the automation process, in moving packages to the next location.

FEATURES & BENEFITS

- Designated space for packages
- Aids in sortation for shipping
- Low noise
- Durable construction
- Ergonomic storage buffer
- Designed for fast installation and ease of maintenance
- Incoming package arrival safety lights alert operators of inbound products
- Accumulation for destination packages

WHAT IT CAN BE USED FOR

- Final automated sortation before loading a truck
- Holds variety of package and mailer sizes and weights
- Final last mile automation for routine sorting
- Improved ergonomics for package sorting

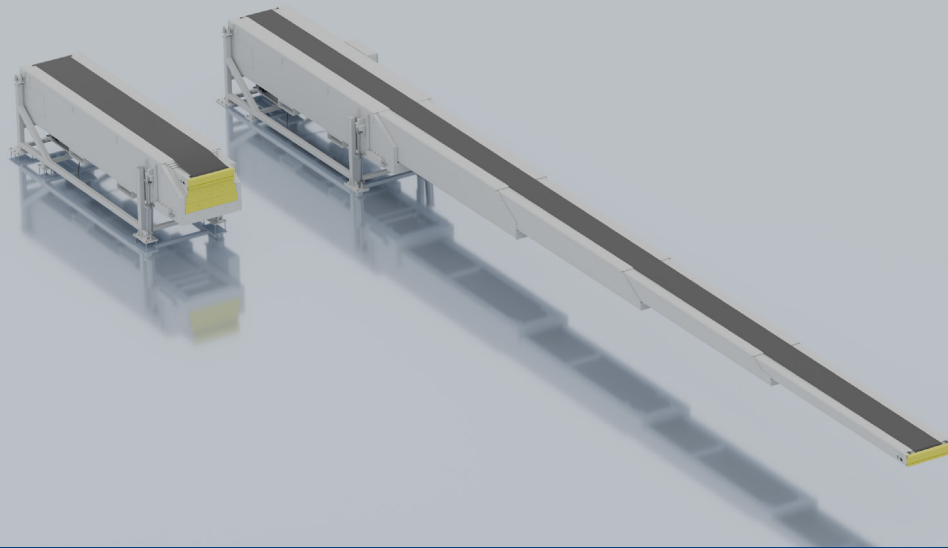

TELESCOPING BOOM CONVEYOR

EXTENDABLE UNLOADER WITH FOUR BOOMS FOR HANDLING PACKAGES

DETAILS

EXTENDED LENGTH: 70'-6"

RETRACTED LENGTH: 18'-9 1/2"

BASE WIDTH: ~4'

BELT WIDTH: 21"

INFEED ELEVATION: 1'-3 1/4" to 5'6"

BOOM TRAVEL SPEED: 40FPM

BELT SPEED: 50, 80, and 100FPM

BELT DRIVE: 3HP Drum motor

CHAIN DRIVE: 1 1/2 HP Geared motor

HYDRAULIC POWERPACK MOTOR: 3HP

LOAD: 50lbs/ft + 250lb at the tip

PRODUCT DETAILS

Telescopic boom conveyors are designed for efficient material handling, featuring hydraulic cylinders for smooth lifting and lowering. It has four synchronously extendable booms, and a robust base for durability and stability in industrial environments. Equipped with safety bumpers at the loading end of the boom for safety to prevent damage in presence of obstacle.

FEATURES & BENEFITS

- Package handling upto 50lbs/ft
- Hydraulic Lift Cylinders to adjust the height to ergonomic power zone
- Safety mechanical bumpers with limit switches as sensors
- Belt misalignments indicated using limit switches
- Easy loading of packages from the truck due to extendable boom into the trailer of the truck
- Cam rollers for guiding the booms to ensure smooth extension and retraction
- Access windows for ease of maintenance of chain drive and belt drive motors
- Variable conveyor belt speed

WHAT IT CAN BE USED FOR

- Extends into trucks and containers to streamline the unloading packages, reducing manual labor
- Used in warehouse operations to convey packages from trucks to trailing conveyors
- Improving efficiency in logistics and supply chain operations.

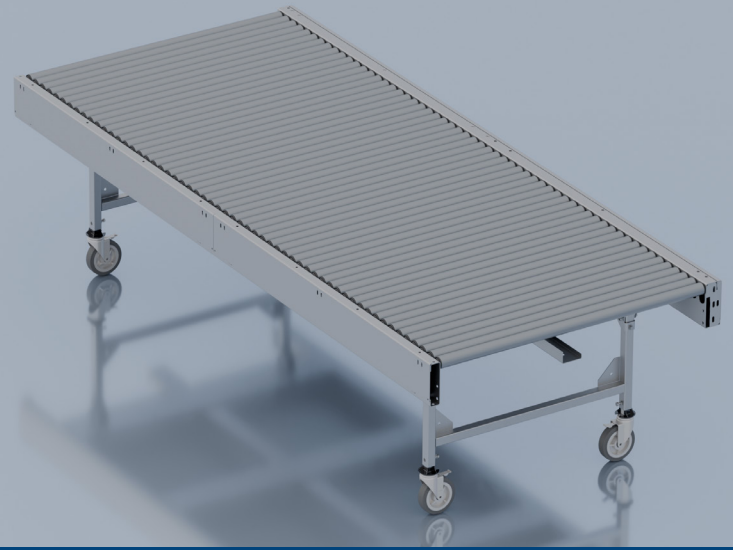

MPRC+ WITH CYBERLOGIQ

QUICKLY DEPLOYABLE CONVEYANCE SYSTEM

DETAILS

CONVEYING WIDTH: 36" OR 48"

The effective conveying width is determined by package size, available floor space, & application specific needs

CONVEYING ELEVATION: 24" - 48"

Standard conveying elevation is 32", but load & unload areas can be lower or higher as needed. Elevations higher & lower than this range can be achieved on a custom basis

LENGTH (STRAIGHT): 60" / 120"

The standard individual straight section is 120" long; these can be coupled together for runs of any length needed. Lengths other than the standard 60" & 120" are available on a custom basis but need to be divisible by the roller centers

DEGREE (CURVED): 30° / 45° / 60° / 90°

90° turns are standard on most systems, but 30°, 45°, & 60° turns are available as needed for special layout situations

PRODUCT DETAILS

We developed an innovative modular conveyor system that is configurable, portable, quiet, durable, & cost-effective. Our Modular Portable Roller Conveyor Plus (MPRC+) system can connect in straight runs up to 80 feet with a single 110v power drop. The system can combine with powered curves to maneuver around existing equipment or building structures. Our configurable conveying system can provide you with the flexibility you need to manage ever-changing markets. What makes this stand out from our standard MPRC is the optional feature for close roller spacing, along with covered bands. Standard spacing is at a 2.1" roller center.

CyberLogiQ isn't just a product—it's a flexible, intelligent solution built to adapt to your needs. Designed to integrate seamlessly with a variety of sensors, control cards and motors. CyberLogiQ optimizes conveyor operations like never before. With features like zoned accumulation, dynamic singulation, merging, and gapping control, it's the key to maximizing efficiency and throughput.

FEATURES & BENEFITS

- Prevents Wear & Tear
- Protects Operators
- Improved Durability, Lower Maintenance

WHAT IT CAN BE USED FOR

- Transportation
- Sortation
- Merging
- Dock Delivery
- Zone Accumulation
- Creating Gaps
- Parcel Fulfillment